

GEM_040, _050 FAMILY

Green Power Easy Module®

Features:

- ▶ Electrically insulated metal frame
- ▶ 3000 V_{RMS} Insulation
- ▶ High reliability
- ▶ Modular approach
- ▶ Broad choice of circuit configurations
- ▶ Fully customizable
- ▶ Cost effective solution
- ▶ Suitable for heavy duty applications
- ▶ Line voltage range up to 690V_{RMS}

Description

This new family of high power diode modules brings to the high power applications the same compactness, ease of use and scalability of the traditional lower power semiconductor modules. In addition to these typical features (i.e. standard dimensions, electrical insulation, various circuit types, etc.) the new *Green Power Easy Module (GEM)* family includes many features that simplify their adoption allowing the end users to focus on their core business. These features include:

- embedded air cooling system (heatsinking and high efficiency fan)
- optimised RC snubber circuits
- ducted heat flow
- protection systems (semiconductor fuses, blown fuse switches, over temperature alarm switch, fan-on-demand function, fan loss detection)
- connection bus bars.

The diode module GEM family can be used for most of the converter circuits like single and three phase bridges, double wye rectifiers, etc.. Their application range covers all standard industrial line voltage applications (up to 690V_{RMS}) such as: electroplating, welding, temperature control, electrolysis, UPS, etc.

Maximum Ratings

Parameters	GEM_040	GEM_050				Conditions	Units
I _{F(AV)}	400	500				180° cond., half sine, T _A =40°C	A
I _{FSM}	17.9	28				50Hz, T _J =T _{J(MAX)} , V _R =0V	kA
I _{FSM}	19	29.6				60Hz, T _J =T _{J(MAX)} , V _R =0V	kA
I ² _t	1602	3920				50Hz, T _J =T _{J(MAX)} , V _R =0V	kA ² s
I ² _t	1759	4300				60Hz, T _J =T _{J(MAX)} , V _R =0V	kA ² s
V _{RRM}	up to 2200	up to 1000				T _J =T _{J(MAX)}	V
T _{J(MAX)}	175	175					°C

Voltage Ratings

Part Number	Voltage Code	V_{RRM} maximum reverse blocking voltage V	I_{RRM} max blocking current @ T_{JMAX} mA	$V_{L(RMS)}$ maximum suggested line RMS voltage V
GEM_040	10	1000	50	280
	12	1200		400
	16	1600		500
	22	2200		690
GEM_050	08	800	50	204
	10	1000		280

Voltage Ratings

Parameters	GEM_040	GEM_050			Conditions	Units
$V_{F(TO)}$ - Threshold voltage	0.85	0.75			$T_J = T_{JMAX}$	V
r_f - Slope resistance	0.26	0.125			$T_J = T_{JMAX}$	m Ω
V_{FM} - Maximum forward voltage	1.30	1.07			$T_J = 25^\circ\text{C} - I_F = 1800\text{A}$	V

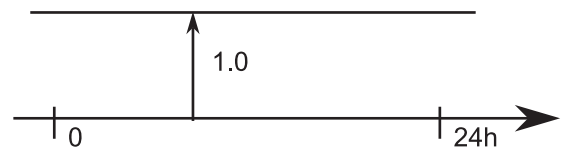

Maximum IEC class 1 output current for typical circuit

Circuit Type	GEM_040	GEM_050				Conditions	Units
Two pulse bridge	800	1000				delay angle=0, $T_A = 40^\circ\text{C}$	A
Six pulse bridge	1200	1500				delay angle=0, $T_A = 40^\circ\text{C}$	A
Double Wye with I.P. transformer	2400	3000				delay angle=0, $T_A = 40^\circ\text{C}$	A

Physical and Mechanical Characteristics

Parameters	GEM_040	GEM_050				Conditions	Units
T _J - Junction operating temp.	175	175					°C
T _{STG} - Storage temperature	-40 / +70	-40 / +70					°C
T _{Mounting} GEM to panel torque ± 10% Busbar to GEM	7	7				M6 mounting screws	Nm
	14	14				M8 mounting screws	Nm
wt - approximate weight	11	11				with VFB options	kg

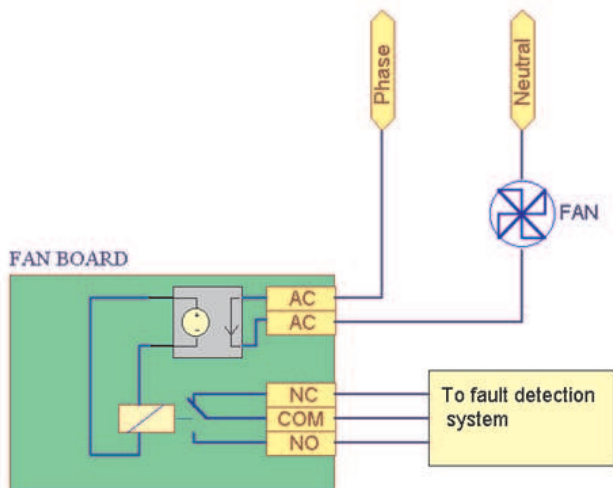
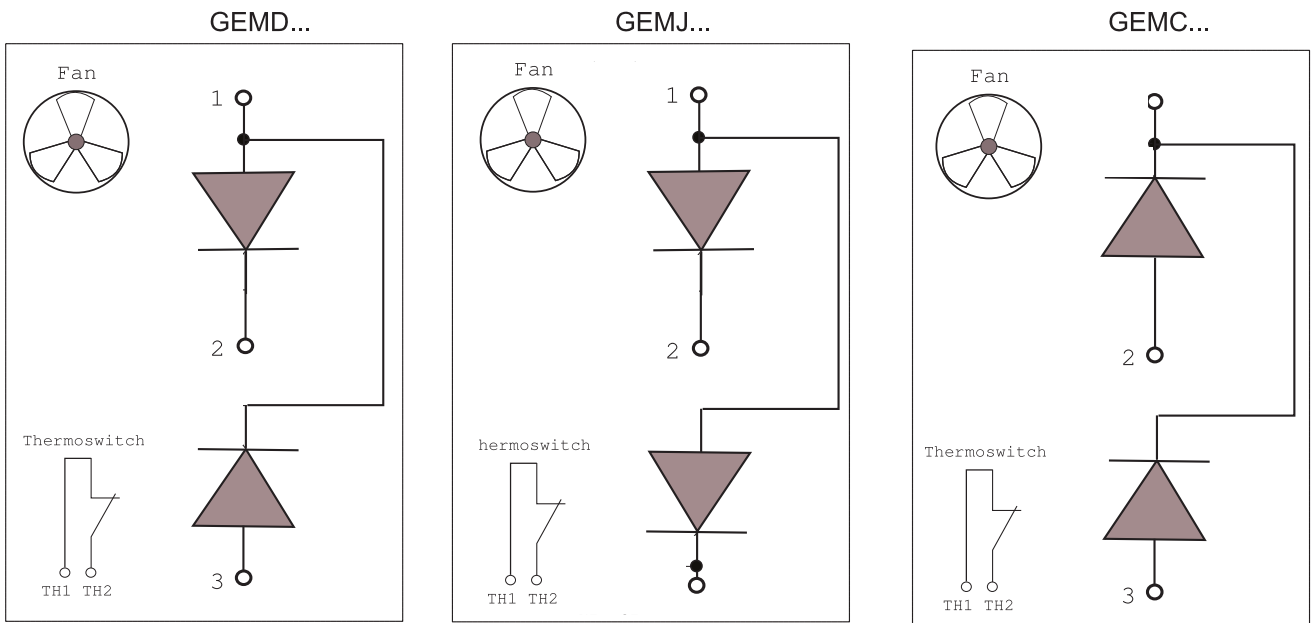
Circuit Configurations



Cooling unit characteristics

Supply voltage: 230V
 Supply freq.: 50-60 Hz
 Supply current: 0.67 A
 Noise: 61dB

Thermoswitch characteristics

Contact type: normally closed
 Switch temp.: 100°C
 Insulation: 2500 V_{DC}

Ordering Information

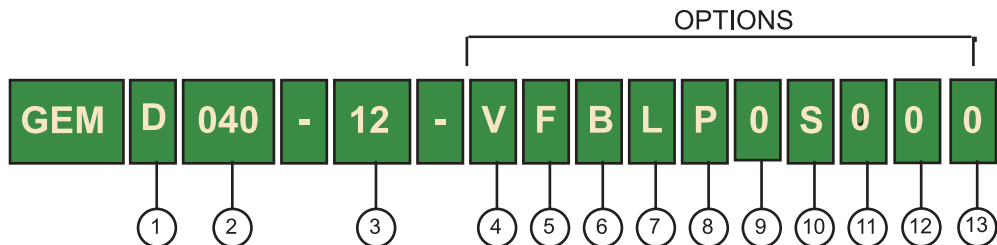

- ① Circuit configuration : D, J, C
- ② GEM average current / 10
- ③ GEM blocking voltage/ 100
- ④ 0= No Fan; V= 230VAC single
- ⑤ 0= No fuse; F= Individual fuse
- ⑥ 0= No busbar; B= With standard copper busbars at terminals
- ⑦ Not applicable
- ⑧ Not applicable
- ⑨ 0= No cooling alarm; C= Cooling alarm available
- ⑩ Not applicable
- ⑪ 0= No RC snubber; 2= Two RC snubbers
- ⑫ 0= Standard Zinc-plated steel body; S= Amagnetic stainless-steel body
- ⑬ 0= No Fan-on-demand; F= fan-on-demand function (Thermoswitch 50°C trip point)