

# GOB9xx20

## BI-DIRECTIONAL THREE PHASE AC-DC BRIDGE

- Fuse protection
- Blown fuse indicators with microswitch
- Over temperature switches
- Fan loss detection circuit
- Snubber for SCR's protections
- Extractible stacks for easy field service

**LINE VOLTAGE UP TO 500V**  
**DC OUTPUT CURRENT 2000 A**

	GOB94020	GOB95020
Line to line voltage	400 V	500 V

Characteristic		Conditions	Value	Value	
I <sub>DC</sub>	DC output current		2000 A	2000 A	
V <sub>INS</sub> (rms)	Insulation voltage		3000 V	3000 V	

### THYRISTOR CHARACTERISTICS

V <sub>GT</sub>	Gate trigger voltage	T <sub>j</sub> = 25 °C, V <sub>D</sub> = 5 V	3 V	3 V	
I <sub>GT</sub>	Gate trigger current	T <sub>j</sub> = 25 °C, V <sub>D</sub> = 5 V	300 mA	300 mA	
dV/dt	Critical rate of rise off-state voltage	T <sub>j</sub> = 125 °C	1000 V/us	1000 V/us	
V <sub>RRM</sub>	Blocking Voltage	T <sub>j</sub> = 125 °C	1200 V	1600 V	

### FUSE TYPE SIBA 2068132.1250

V <sub>NF</sub>	Rated voltage		690 V	690 V	
I <sub>NF</sub>	Rated current		1250 A	1250 A	
P <sub>VF</sub>	Power loss	At rated current	147 W	147 W	
I <sup>2</sup> <sub>t</sub>	Total I <sup>2</sup> <sub>t</sub>	At 660V	1750 kA <sup>2</sup> s	1750 kA <sup>2</sup> s	

### MECHANICAL AND THERMAL CHARACTERISTICS

	Width		500 mm	500 mm	
	Depth		375 mm	375 mm	
	Height		1405 mm	1405 mm	
	Mass		130 kg	130 kg	
T <sub>a max</sub>	Max amb. op. Temp.		40 °C	40 °C	
T <sub>stg</sub>	Storage temperature		-40/60 °C	-40/60 °C	

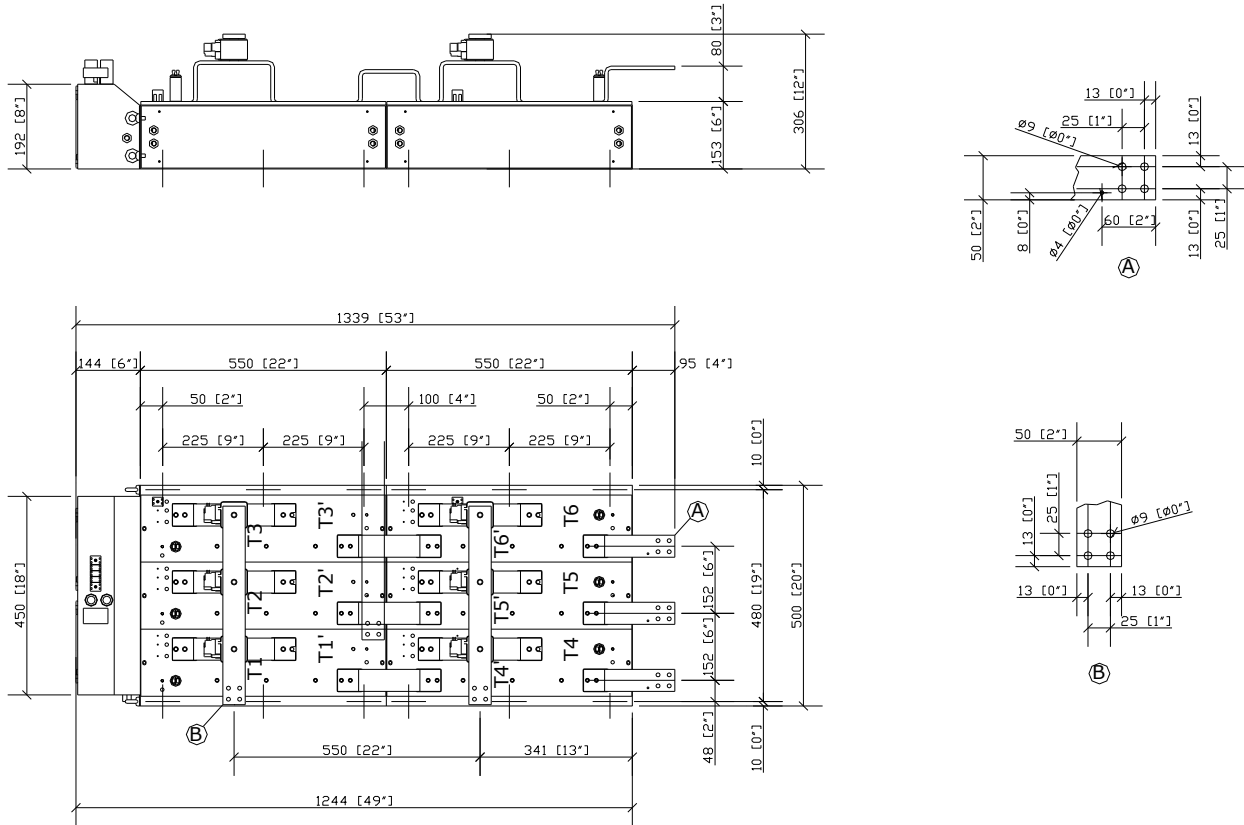

The part numbering system is reported at the beginning of the Open Assembly section.

Customisations are available on request. Please contact factory.

In the interest of product improvement Green Power Solutions reserves the right to change any specification given in this data sheet without notice.



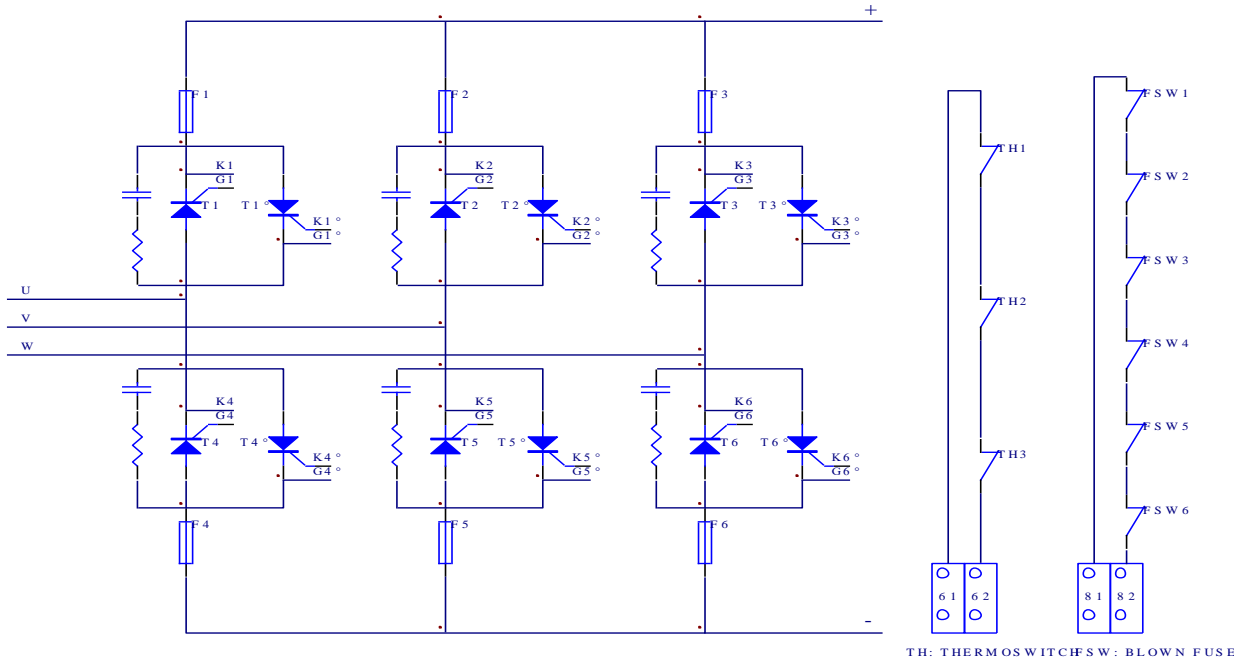

6 1 -6 2 : THERMOSWITCH CIRCUIT CONNECTION  
8 1 -8 2 : BLOWN FUSE SWITCH CIRCUIT CONNECTION

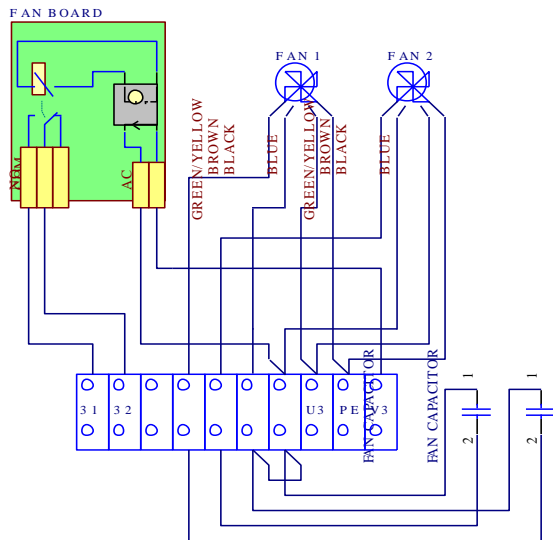

U3 -V3 : MAIN SUPPLY  
PE : GROUND CONNECTION (GND)  
3 1 -3 2 : FAN BOARD CONTACT (CLOSED WHEN FAN RUNNING)

**Cooling:**

Fan type: single phase axial  
 Number of fans: 2  
 Voltage: 230 V  
 Current: 0.4 A  
 Frequency: 50/60 Hz  
 Noise: 62 dBA

In the interest of product improvement Green Power Solutions reserves the right to change any specification given in this data sheet without notice.