

GOB9xx23

BI-DIRECTIONAL THREE PHASE AC-DC BRIDGE

- Fuse protection
- Blown fuse indicators with microswitch
- Over temperature switches
- Fan loss detection circuit
- Snubber for SCR's protections
- Extractible stacks for easy field service

LINE VOLTAGE UP TO 500V
DC OUTPUT CURRENT 2300A

GOB94023 GOB95023

Line to line voltage	400 V	500 V	
----------------------	-------	-------	--

Characteristic		Conditions	Value	Value	
I _{DC}	DC output current		2300 A	2300 A	
V _{INS} (rms)	Insulation voltage		3000 V	3000 V	

THYRISTOR CHARACTERISTICS

V _{GT}	Gate trigger voltage	T _j = 25 °C, V _D = 5 V	3 V	3 V	
I _{GT}	Gate trigger current	T _j = 25 °C, V _D = 5 V	300 mA	300 mA	
dV/dt	Critical rate of rise off-state voltage	T _j = 125 °C	1000 V/us	1000 V/us	
V _R RM	Blocking Voltage	T _j = 125 °C	1200 V	1600 V	

FUSE TYPE SIBA 268132.1400

V _{NF}	Rated voltage		690 V	690 V	
I _{NF}	Rated current		1400 A	1400 A	
P _{VF}	Power loss	At rated current	161 W	161 W	
I ² t	Total I ² t	At 660V	2200 kA ² s	2200 kA ² s	

MECHANICAL AND THERMAL CHARACTERISTICS

	Width		620 mm	620 mm	
	Depth		420 mm	420 mm	
	Height		1409 mm	1409 mm	
	Mass		170 kg	170 kg	
T _a max	Max amb. op. Temp.		40 °C	40 °C	
T _{stg}	Storage temperature		-40/60 °C	-40/60 °C	

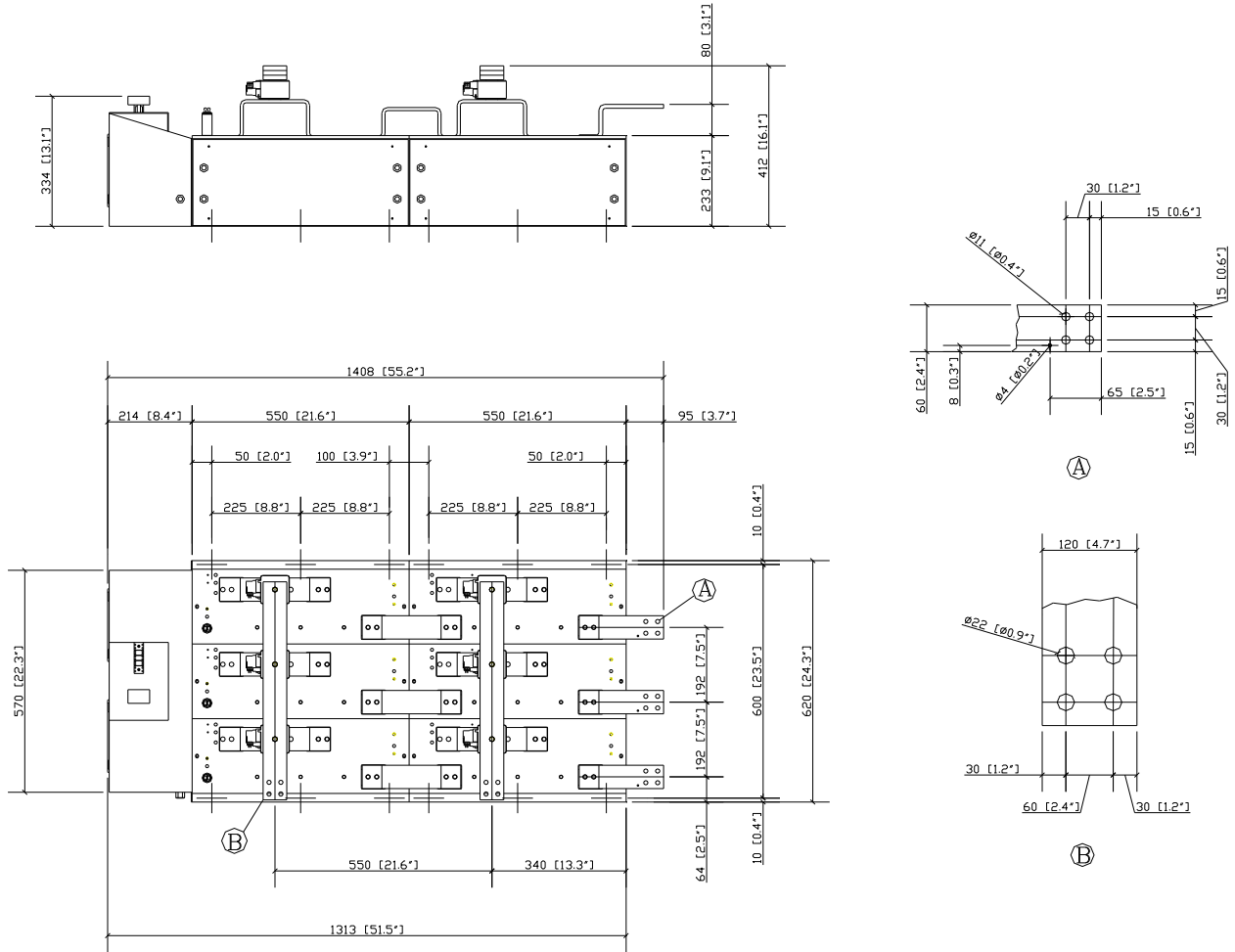

The part numbering system is reported at the beginning of the Open Assembly section.

Customisations are available on request. Please contact factory.

In the interest of product improvement Green Power Solutions reserves the right to change any specification given in this data sheet without notice.

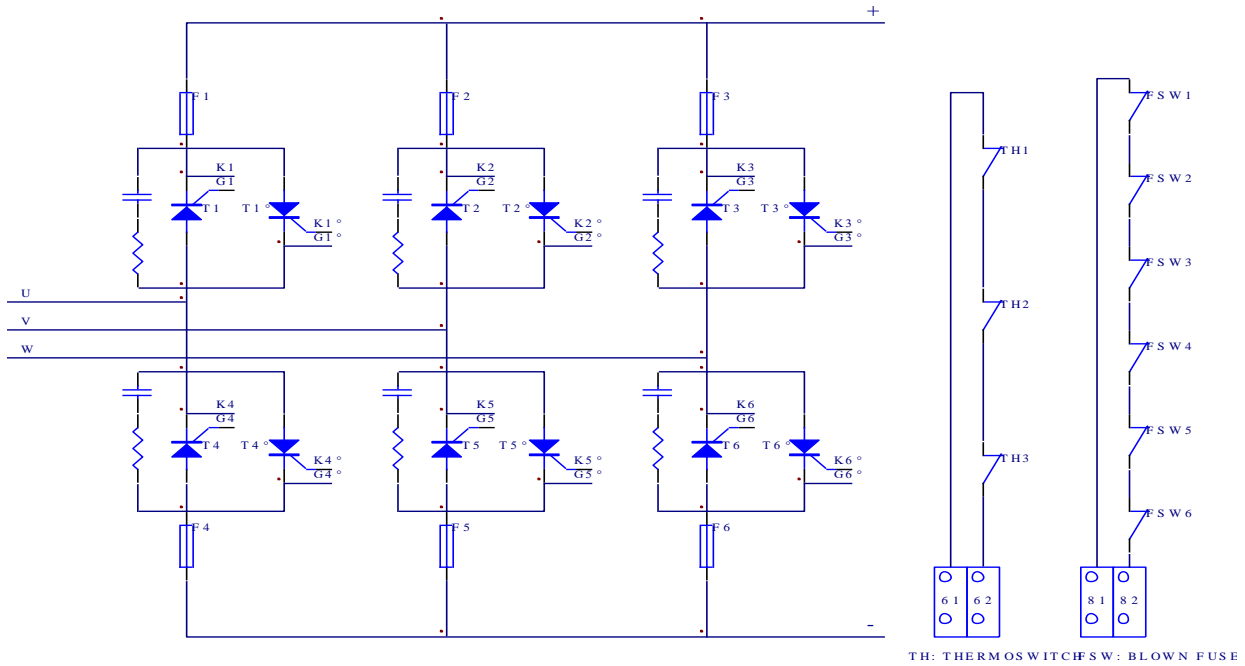

61-62: THERMOSWITCH CIRCUIT CONNECTION
81-82: BLOWN FUSE SWITCH CIRCUIT CONNECTION

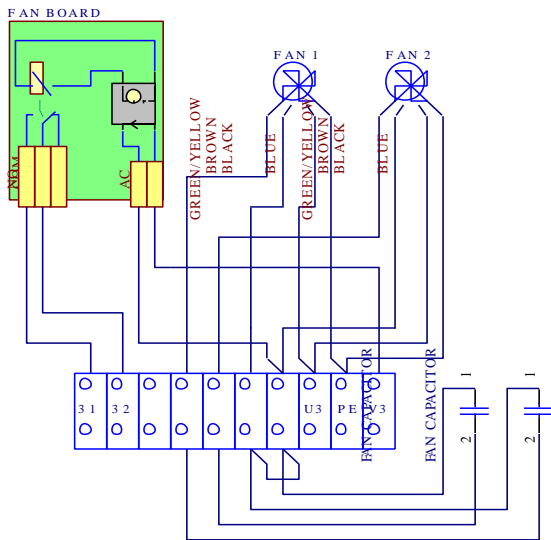

U3-V3: MAIN SUPPLY
PE: GROUND CONNECTION (GND)
31-32: FAN BOARD CONTACT (CLOSED WHEN FAN RUNNING)

Cooling:

Fan type: single phase axial
 Number of fans: 2
 Voltage: 230 V
 Current: 0.6 A
 Frequency: 50/60 Hz
 Noise: 62 dBA

In the interest of product improvement Green Power Solutions reserves the right to change any specification given in this data