

GOB9xx27

Bi-DIRECTIONAL THREE PHASE AC-DC BRIDGE

Fuse protection
 Blown fuse indicators with microswitch
 Over temperature switches
 Fan loss detection circuit
 Snubber for SCR's protections
 Extractible stacks for easy field service

LINE VOLTAGE UP TO 690V
DC OUTPUT CURRENT 2700A

GOB94027 GOB95027 GOB96027

Line to line voltage	400 V	500 V	690 V
----------------------	--------------	--------------	--------------

Characteristic		Conditions	Value	Value	Value
I _{DC}	DC output current		2700 A	2700 A	2700 A
V _{INS} (rms)	Insulation voltage		3000 V	3000 V	3000 V

THYRISTOR CHARACTERISTICS

V _{GT}	Gate trigger voltage	T _j = 25 °C, V _D = 5 V	3 V	3 V	3 V
I _{GT}	Gate trigger current	T _j = 25 °C, V _D = 5 V	400 mA	400 mA	400 mA
dV/dt	Critical rate of rise off-state voltage	T _j = 125 °C	1000 V/us	1000 V/us	1000 V/us
V _{RRM}	Blocking Voltage	T _j = 125 °C	1200 V	1600 V	2200 V

FUSE TYPE 12x SIBA 2068132.800 / 2078132.800

V _{NF}	Rated voltage		690 V	690 V	1250 V
I _{NF}	Rated current		800 A	800 A	800 A
P _{VF}	Power loss	At rated current	118 W	118 W	135 W
I ² t	Total I ² t	At 660/1000 V	480 kA ² s	480 kA ² s	1070 kA ² s

MECHANICAL AND THERMAL CHARACTERISTICS

	Width		712 mm	712 mm	642 mm
	Depth		495 mm	495 mm	427 mm
	Height		1635 mm	1635 mm	1330 mm
	Mass		260 kg	260 kg	260 kg
T _{a max}	Max amb. op. Temp.		40 °C	40 °C	40 °C
T _{stg}	Storage temperature		-40/60 °C	-40/60 °C	-40/60 °C

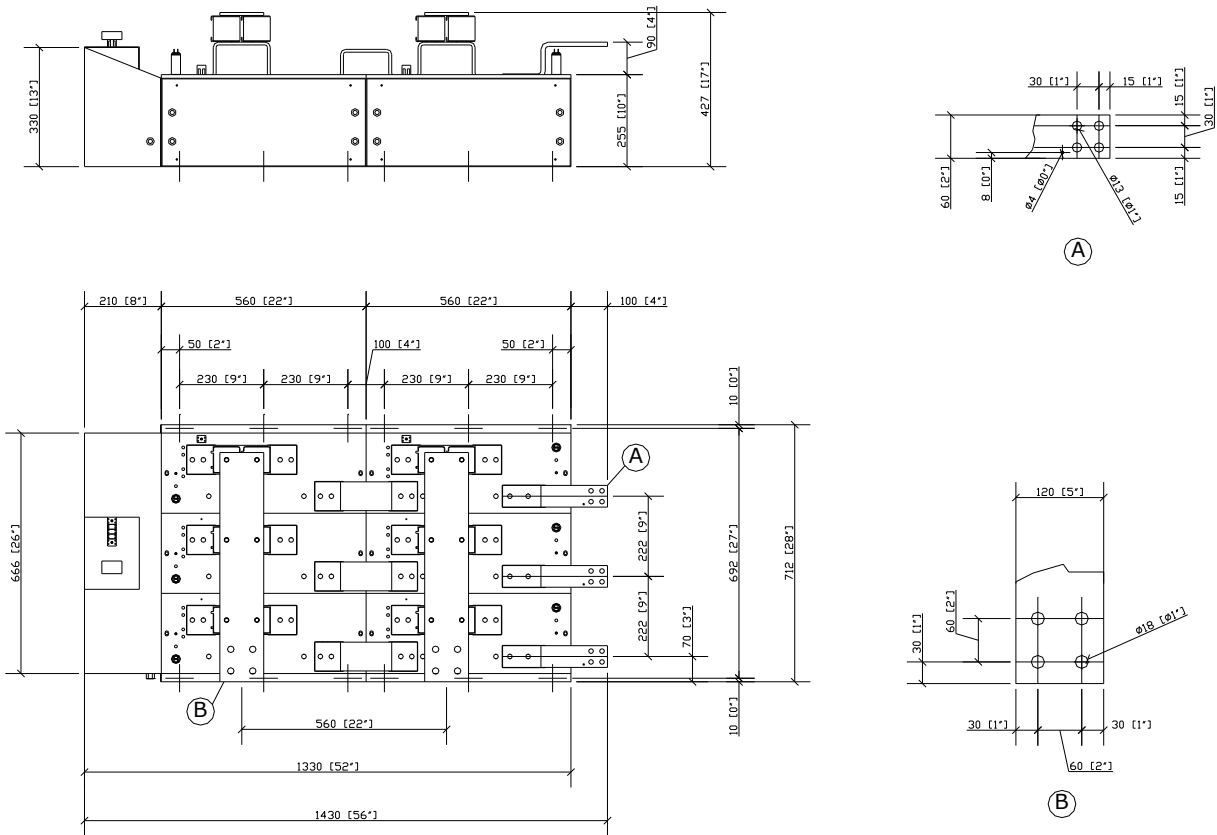

The part numbering system is reported at the beginning of the Open Assembly section.

Customisations are available on request. Please contact factory.

In the interest of product improvement Green Power Solutions reserves the right to change any specification given in this data sheet without notice.

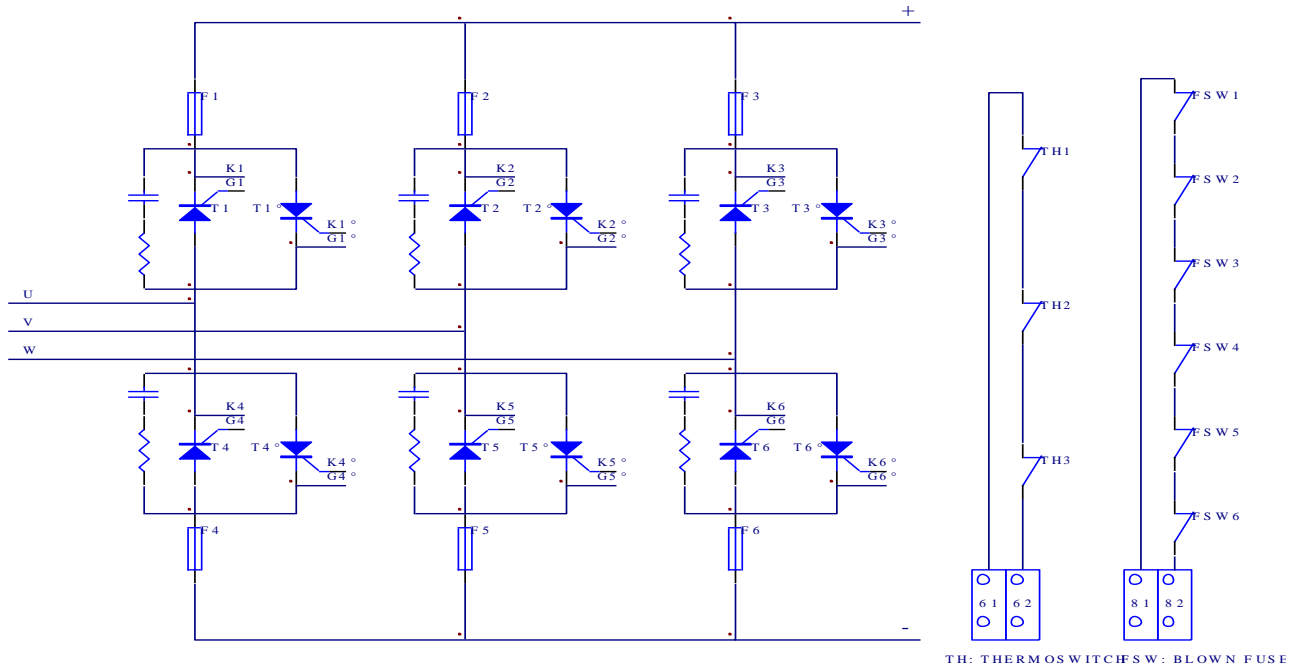

6.1-6.2: THERMOSWITCH CIRCUIT CONNECTION
8.1-8.2: BLOWN FUSE SWITCH CIRCUIT CONNECTION

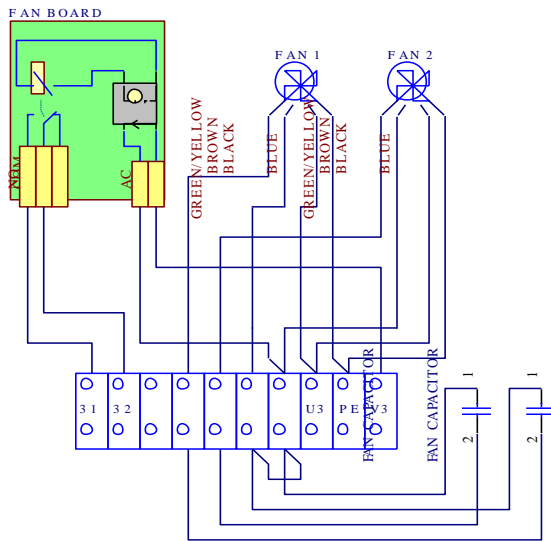

U3-V3: MAIN SUPPLY
PE: GROUND CONNECTION (GND)
3.1-3.2: FAN BOARD CONTACT (CLOSED WHEN FAN RUNNING)

Cooling:

Fan type: single phase axial
 Number of fans: 2
 Voltage: 230 V
 Current: 1.3 A
 Frequency: 50/60 Hz
 Noise: 62 dBA

In the interest of product improvement Green Power Solutions reserves the right to change any specification given in this data sheet without notice.