

GOG9xx29

THREE PHASE AC-DC BRIDGE

- Fuse protection
- Blown fuse indicators with microswitch
- Over temperature switches
- Fan loss detection circuit
- Snubber for SCR's protections
- Extractible stacks for easy field service

LINE VOLTAGE UP TO 500V

DC OUTPUT CURRENT 2900 A

GOG94029 GOG95029

Line to line voltage	400 V	500 V	
----------------------	--------------	--------------	--

Characteristic		Conditions	Value	Value	
I _{DC}	DC output current		2900 A	2900 A	
V _{INS} (rms)	Insulation voltage		3000 V	3000 V	

THYRISTOR CHARACTERISTICS

V _{GT}	Gate trigger voltage	T _j = 25 °C, V _b = 5 V	3 V	3 V	
I _{GT}	Gate trigger current	T _j = 25 °C, V _b = 5 V	400 mA	400 mA	
dV/dt	Critical rate of rise off-state voltage	T _j = 125 °C	1000 V/us	1000 V/us	
V _{RRM}	Blocking Voltage	T _j = 125 °C	1200 V	1600 V	

FUSE TYPE: 2 x SIBA 2068132.900

V _{NF}	Rated voltage		690 V	690 V	
I _{NF}	Rated current		800 A	800 A	
P _{VF}	Power loss	At rated current	120 W	120 W	
I ² _t	Total I ² _t	At 660 V	660 kA ² s	660 kA ² s	

MECHANICAL AND THERMAL CHARACTERISTICS

	Width		500 mm	500 mm	
	Depth		275 mm	275 mm	
	Height		935 mm	935 mm	
	Mass		140 kg	140 kg	
T _{a max}	Max amb. op. Temp.		40 °C	40 °C	
T _{stg}	Storage temperature		-40/60 °C	-40/60 °C	

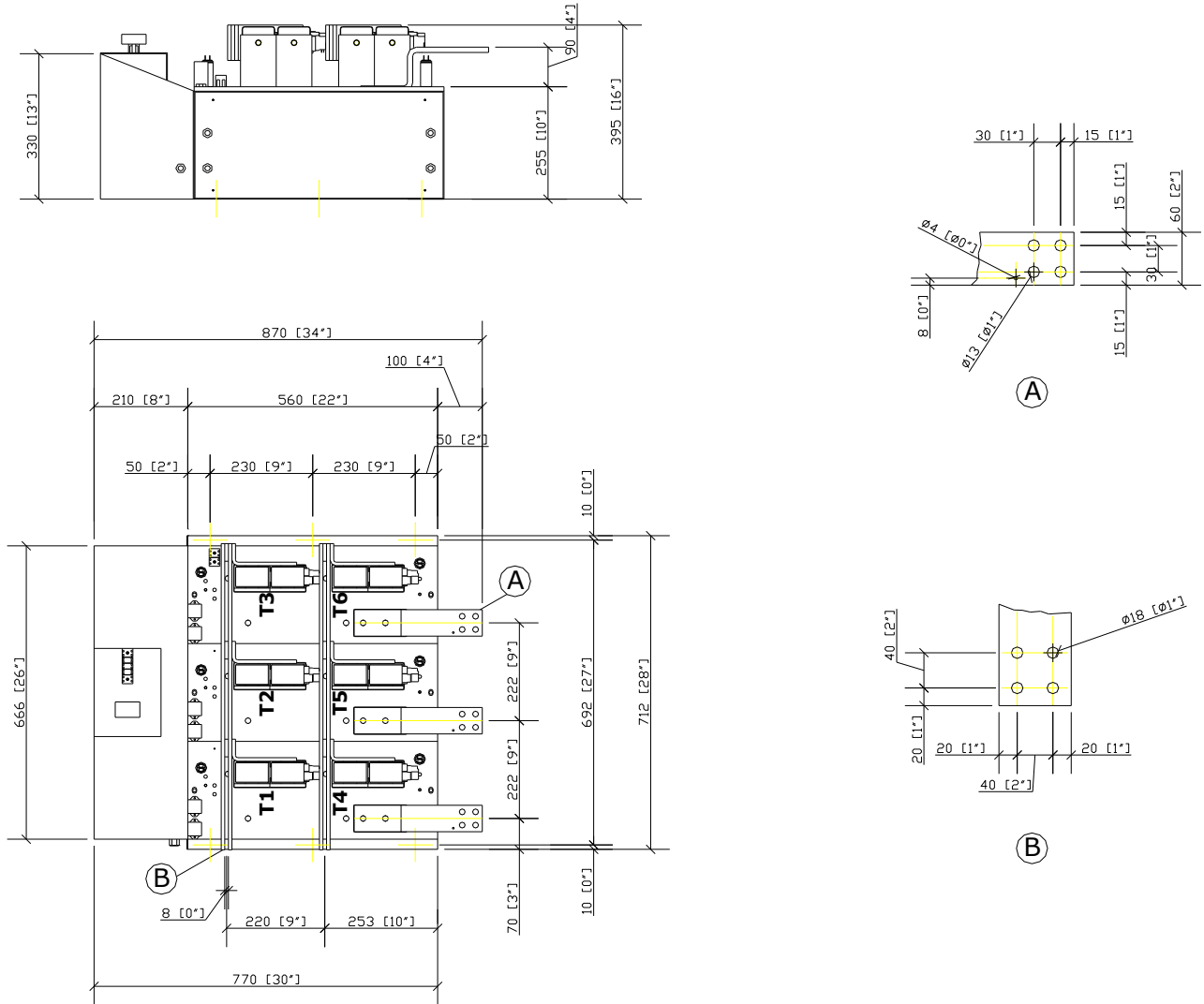

The part numbering system is reported at the beginning of the Open Assembly section.

Customisations are available on request. Please contact factory.

In the interest of product improvement Green Power Solutions reserves the right to change any specification given in this data sheet without notice.

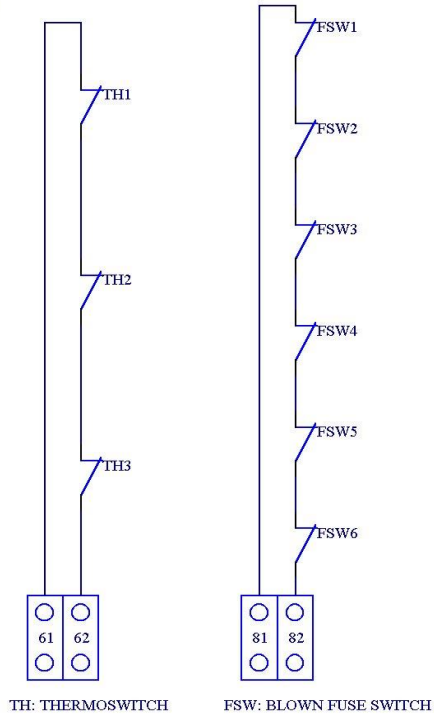
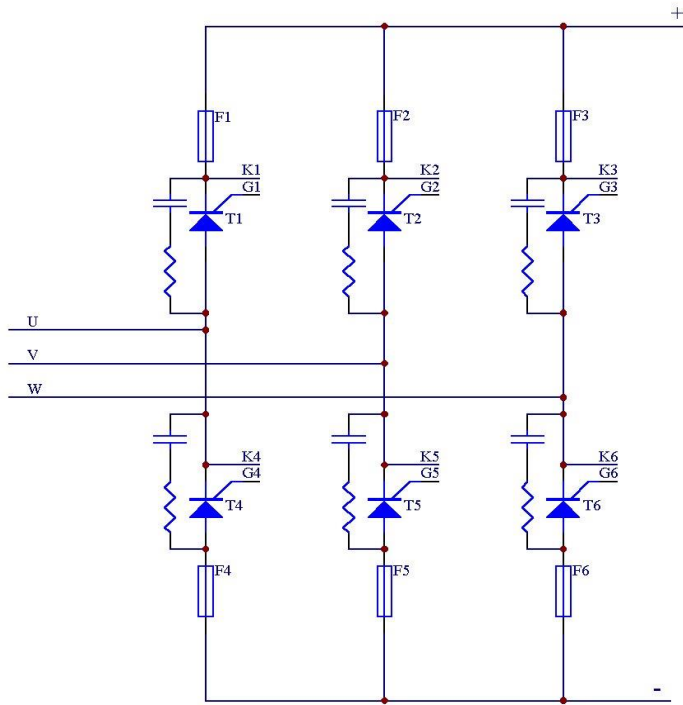

TH: THERMOSWITCH

FSW: BLOWN FUSE SWITCH

61-62: THERMOSWITCH CIRCUIT CONNECTION
81-82: BLOWN FUSE SWITCH CIRCUIT CONNECTION

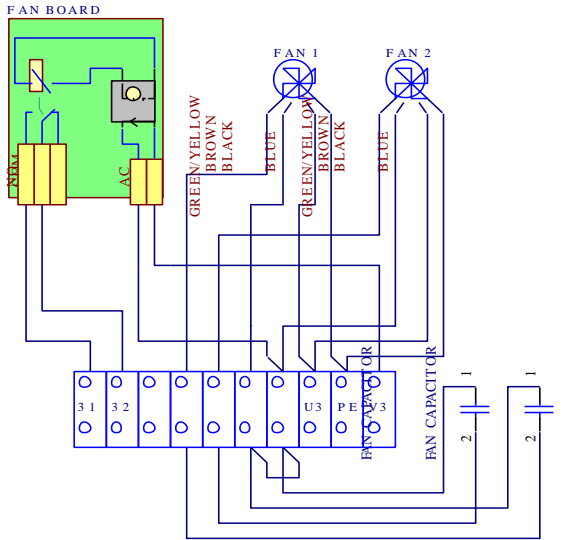

U3 -V3 : M A I N S U P P L Y
PE : G R O U N D C O N N E C T I O N (G N D)
3 1 - 3 2 : F A N B O A R D C O N T A C T (C L O S E D W H E N F A N R U N N I N G)

Cooling:

Fan type: single phase axial
Number of fans: 2
Voltage: 230 V
Current: 1.3 A
Frequency: 50/60 Hz
Noise: 62 dBA

In the interest of product improvement Green Power Solutions reserves the right to change any specification given in this data sheet without notice.