

GOG9xx34

THREE PHASE AC-DC BRIDGE

- Fuse protection
- Blown fuse indicators with microswitch
- Over temperature switches
- Fan loss detection circuit
- Snubber for SCR's protections
- Extractible devices for easy field service

LINE VOLTAGE UP TO 690V

DC OUTPUT CURRENT 3400A

GOG94034 GOG95034 GOG96034

Line to line voltage	400	500	690
----------------------	------------	------------	------------

Characteristic		Conditions	Value	Value	Value
I _{DC}	DC output current		3400 A	3400 A	3400 A
V _{INS} (rms)	Insulation voltage		3000 V	3000 V	3000 V

THYRISTOR CHARACTERISTICS

V _{GT}	Gate trigger voltage	T _j = 25 °C, V _D = 5 V	3 V	3 V	3 V
I _{GT}	Gate trigger current	T _j = 25 °C, V _D = 5 V	500 mA	500 mA	500 mA
dV/dt	Critical rate of rise off-state voltage	T _j = 125 °C	1000 V/us	1000 V/us	1000 V/us
V _{RRM}	Blocking Voltage	T _j = 125 °C	1200 V	1600 V	2200 V

FUSE TYPE SIBA 2 x 2068132.1250

V _{NF}	Rated voltage		690 V	690 V	690 V
I _{NF}	Rated current		1250 A	1250 A	1250 A
P _{VF}	Power loss	At rated current	147 W	147 W	147 W
I ² t	Total I ² t	At 660V	1750 kA ² s	1750 kA ² s	1750 kA ² s

MECHANICAL AND THERMAL CHARACTERISTICS

	Width		780 mm	780 mm	780 mm
	Depth		470 mm	470 mm	470 mm
	Height		1150 mm	1150 mm	1150 mm
	Mass		260 kg	260 kg	260 kg
T _{a max}	Max amb. op. Temp.		40 °C	40 °C	40 °C
T _{stg}	Storage temperature		-40/60 °C	-40/60 °C	-40/60 °C

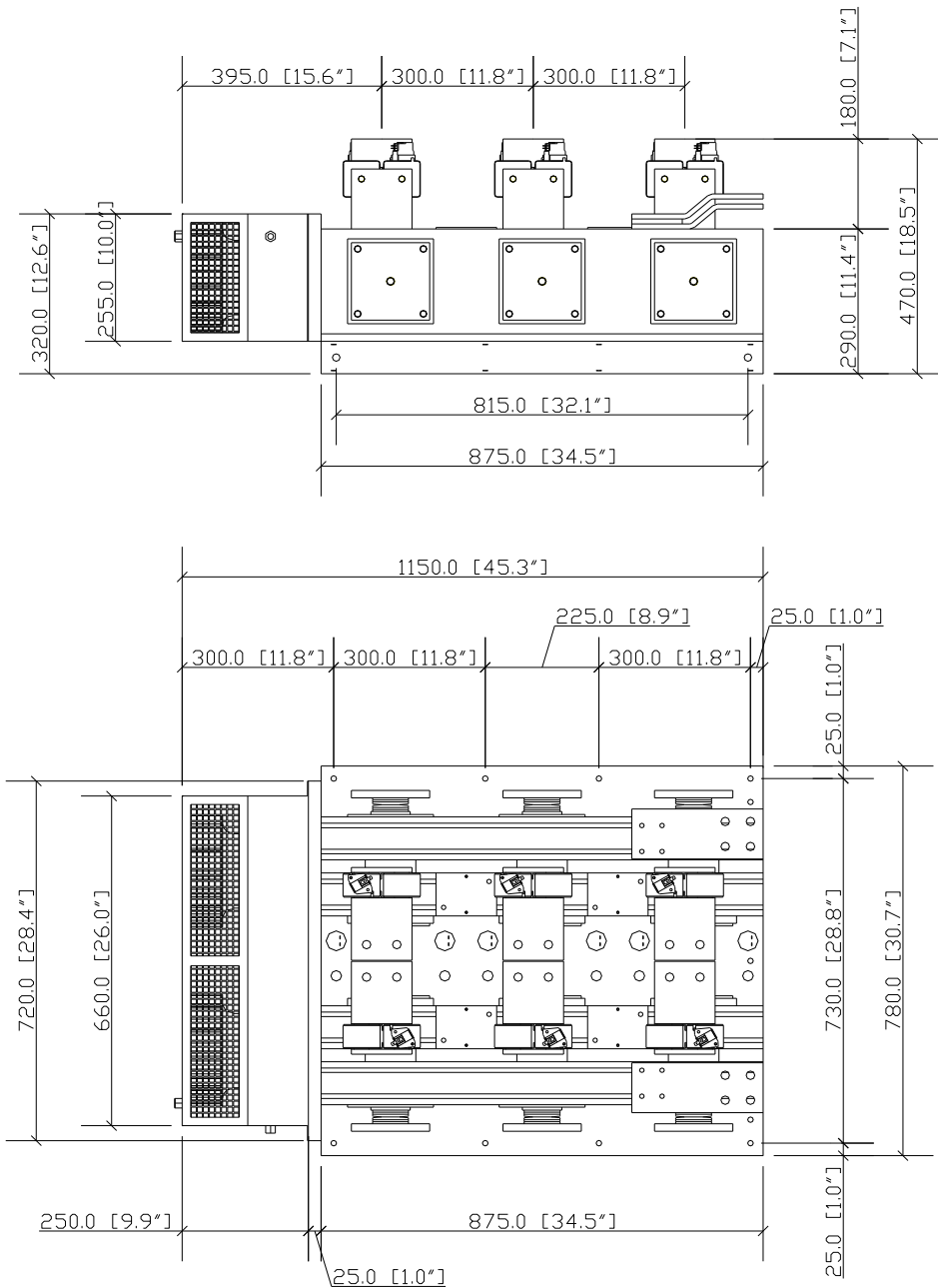

The part numbering system is reported at the beginning of the Open Assembly section.

Customisations are available on request. Please contact factory.

In the interest of product improvement Green Power Solutions reserves the right to change any specification given in this data sheet without notice.

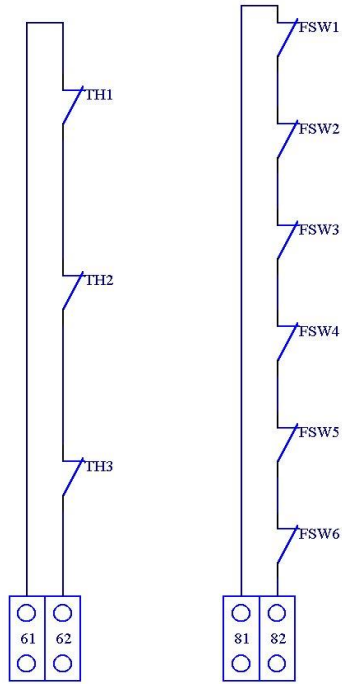
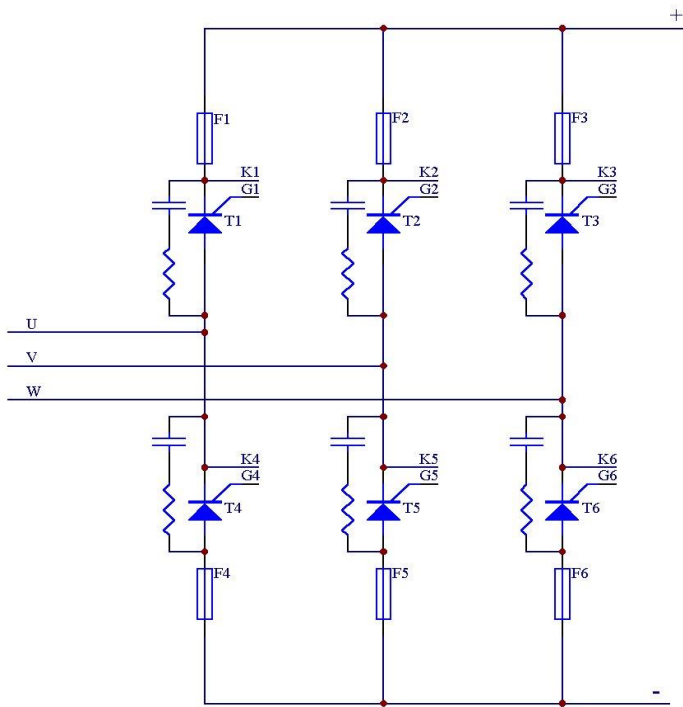

TH: THERMOSWITCH

FSW: BLOWN FUSE SWITCH

61-62: THERMOSWITCH CIRCUIT CONNECTION
81-82: BLOWN FUSE SWITCH CIRCUIT CONNECTION

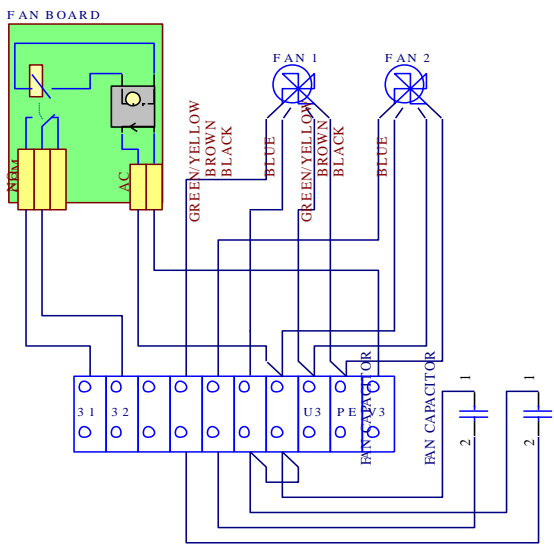

U3-V3: MAIN SUPPLY
PE: GROUND CONNECTION (GND)
3 1-3 2: FAN BOARD CONTACT (CLOSED WHEN FAN RUNNING)

Cooling:

- Fan type: single phase axial
- Number of fans: 2
- Voltage: 230 V
- Current: 1.8 A
- Frequency: 50/60 Hz
- Noise: 70 dBA

In the interest of product improvement Green Power Solutions reserves the right to change any specification given in this data sheet without notice.