

GOG9xx15

THREE PHASE AC-DC BRIDGE

Fuse protection
Blown fuse indicators with microswitch
Over temperature switches
Fan loss detection circuit
Snubber for SCR's protections
Extractible stacks for easy field service

LINE VOLTAGE UP TO 690V
DC OUTPUT CURRENT 1500A

GOG94015 GOG95015 GOG96015

Line to line voltage	400 V	500 V	690 V
----------------------	--------------	--------------	--------------

Characteristic		Conditions	Value	Value	Value
I _{DC}	DC output current		1500 A	1500 A	1500 A
V _{INS} (rms)	Insulation voltage		3000 V	3000 V	3000 V

THYRISTOR TRIGGERING CHARACTERISTICS

V _{GT}	Gate trigger voltage	T _j = 25 °C, V _D = 5 V	3 V	3 V	3 V
I _{GT}	Gate trigger current	T _j = 25 °C, V _D = 5 V	300 mA	300 mA	300 mA
dV/dt	Critical rate of rise off-state voltage	T _j = 125 °C	1000 V/us	1000 V/us	1000 V/us
V _{RRM}	Blocking Voltage	T _j = 125 °C	1200 V	1600 V	2200 V

FUSE TYPE SIBA 2068132.1000 / 2078132.1000

V _{NF}	Rated voltage		690 V	690 V	690 V
I _{NF}	Rated current		1000 A	1000 A	1000 A
P _{VF}	Power loss	At rated current	131 W	131 W	131 W
I ² _t	Total I ² _t	At 660V	860 kA ² s	860 kA ² s	860 kA ² s

MECHANICAL AND THERMAL CHARACTERISTICS

	Width		500 mm	500 mm	500 mm
	Depth		275 mm	275 mm	275 mm
	Height		855 mm	855 mm	855 mm
	Mass		70 kg	70 kg	70 kg
T _{a max}	Max amb. op. Temp.		40 °C	40 °C	40 °C
T _{stg}	Storage temperature		-40/60 °C	-40/60 °C	-40/60 °C

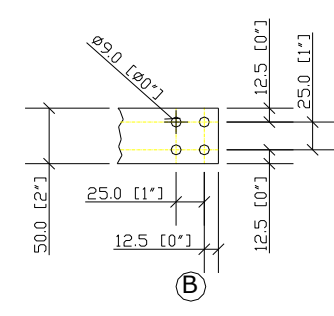
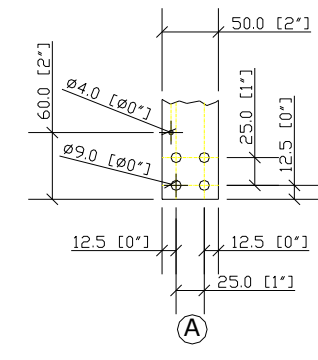
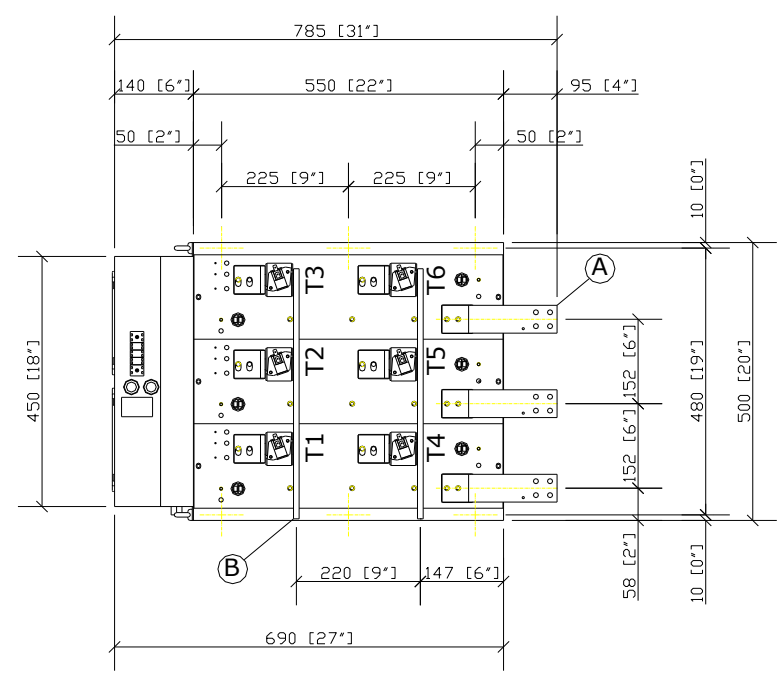
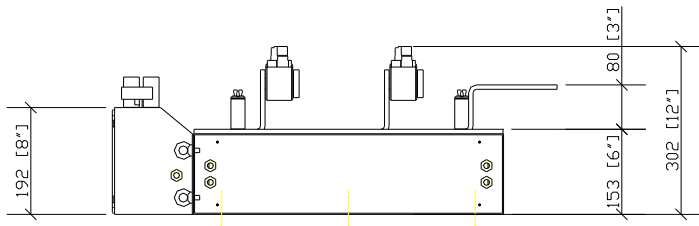

The part numbering system is reported at the beginning of the Open Assembly section.

Customisations are available on request. Please contact factory.

In the interest of product improvement Green Power Solutions reserves the right to change any specification given in this data sheet without notice.

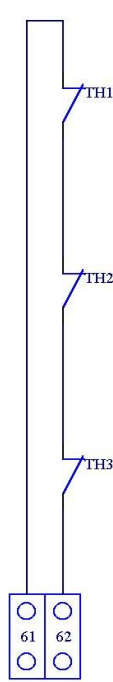
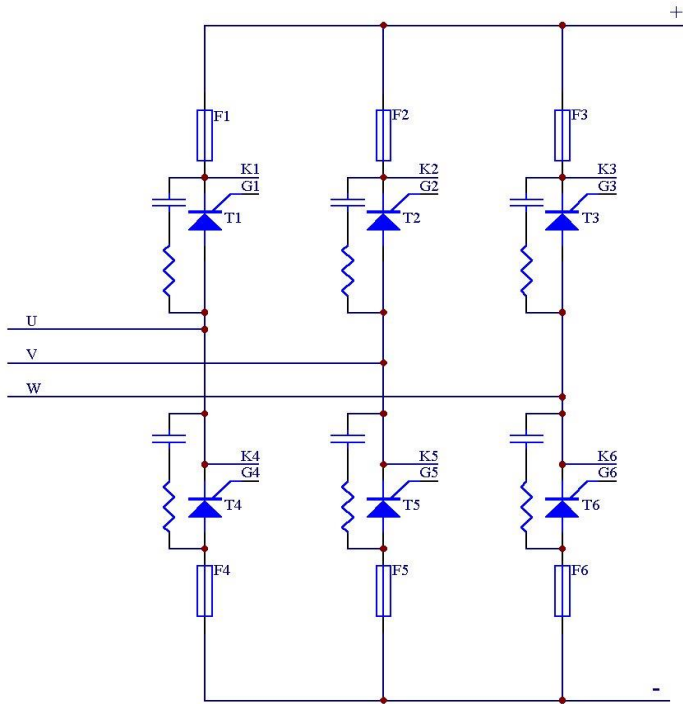

TH: THERMOSWITCH

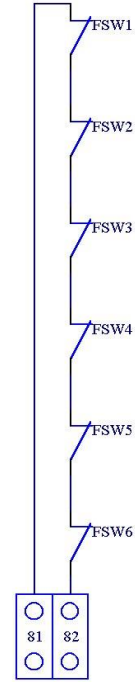

FSW: BLOWN FUSE SWITCH

61-62: THERMOSWITCH CIRCUIT CONNECTION
81-82: BLOWN FUSE SWITCH CIRCUIT CONNECTION

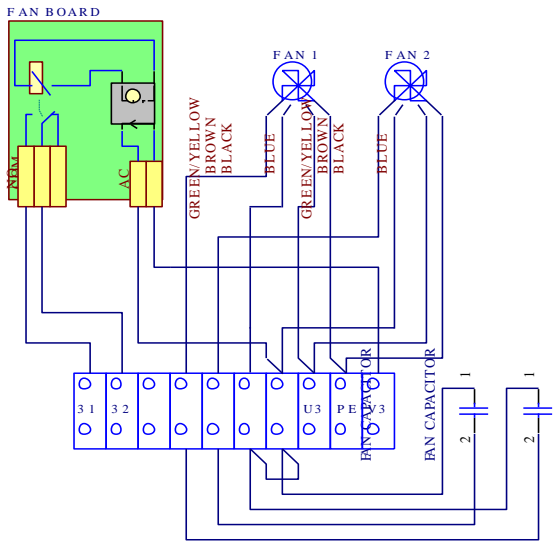

U3-V3: MAIN SUPPLY
PE: GROUND CONNECTION (GND)
31-32: FAN BOARD CONTACT (CLOSED WHEN FAN RUNNING)

Cooling:

Fan type:	single phase axial
Number of fans:	2
Voltage:	230 V
Current:	0.4 A
Frequency:	50/60 Hz
Noise:	62 dBA

In the interest of product improvement Green Power Solutions reserves the right to change any specification given in this data sheet without notice.