

GOG9xx23

THREE PHASE AC-DC BRIDGE

- Fuse protection
- Blown fuse indicators with microswitch
- Over temperature switches
- Fan loss detection circuit
- Snubber for SCR's protections
- Extractable stacks for easy field service

LINE VOLTAGE UP TO 500V

DC OUTPUT CURRENT 2300A

GOG94023 GOG95023

Line to line voltage	400	500	
----------------------	------------	------------	--

Characteristic		Conditions	Value	Value	Value
I _{DC}	DC output current		2300 A	2300 A	
V _{INS} (rms)	Insulation voltage		3000 V	3000 V	

THYRISTOR CHARACTERISTICS

V _{GT}	Gate trigger voltage	T _j = 25 °C, V _D = 5 V	3 V	3 V	
I _{GT}	Gate trigger current	T _j = 25 °C, V _D = 5 V	300 mA	300 mA	
dV/dt	Critical rate of rise off-state voltage	T _j = 125 °C	1000 V/us	1000 V/us	
V _{RRM}	Blocking Voltage	T _j = 125 °C	1200 V	1600 V	

FUSE TYPE SIBA 2068132.1400

V _{NF}	Rated voltage		690 V	690 V	
I _{NF}	Rated current		1400 A	1400 A	
P _{VF}	Power loss	At rated current	161 W	161 W	
I ² t	Total I ² t	At 660V	2200 kA ² s	2200 kA ² s	

MECHANICAL AND THERMAL CHARACTERISTICS

	Width		620 mm	620 mm	
	Depth		360 mm	360 mm	
	Height		855 mm	855 mm	
	Mass		100 kg	100 kg	
T _a max	Max amb. op. Temp.		40 °C	40 °C	
T _{stg}	Storage temperature		-40/60 °C	-40/60 °C	

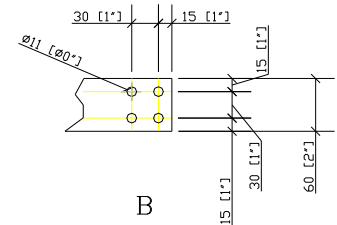
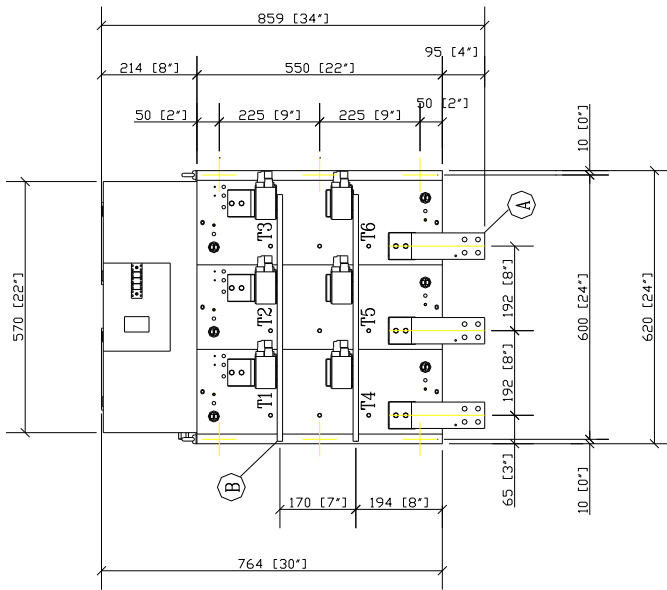
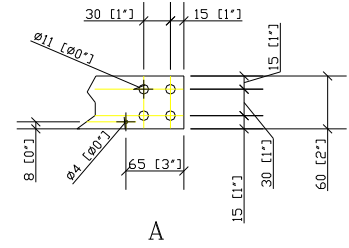
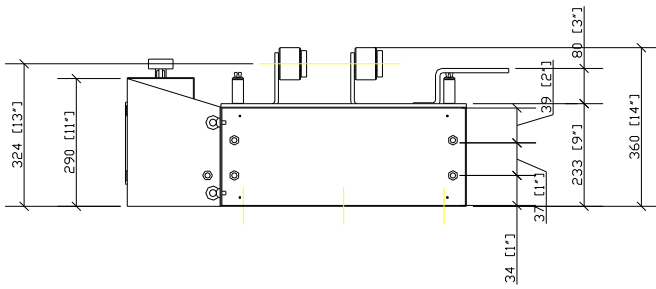

The part numbering system is reported at the beginning of the Open Assembly section.

Customisations are available on request. Please contact factory.

In the interest of product improvement Green Power Solutions reserves the right to change any specification given in this data sheet without notice.

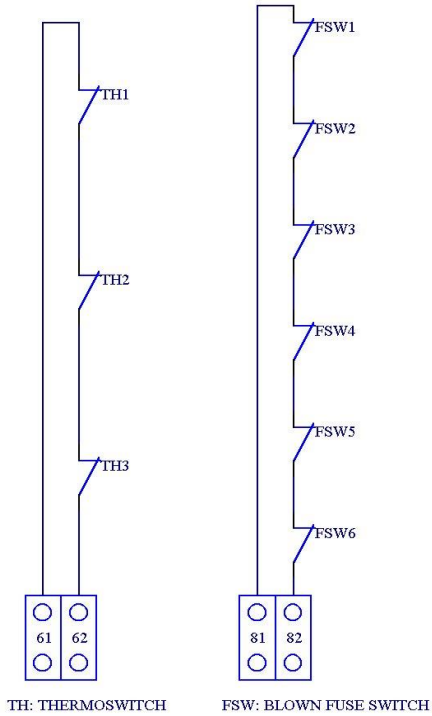
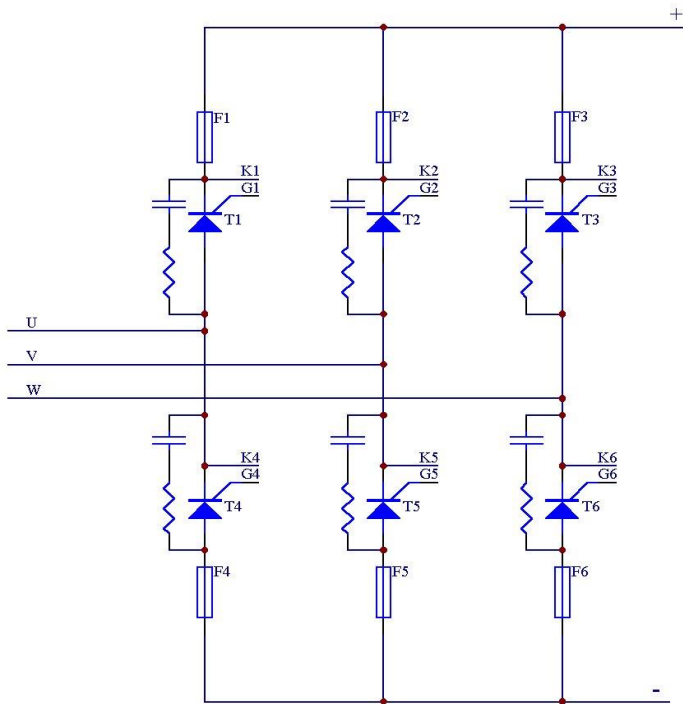

61-62: THERMOSWITCH CIRCUIT CONNECTION
81-82: BLOWN FUSE SWITCH CIRCUIT CONNECTION

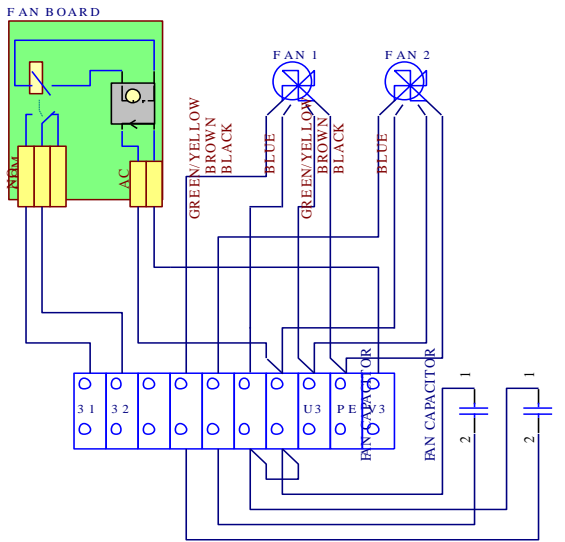

U3-V3: MAIN SUPPLY
PE: GROUND CONNECTION (GND)
31-32: FAN BOARD CONTACT (CLOSED WHEN FAN RUNNING)

Cooling:

- Fan type: single phase axial
- Number of fans: 2
- Voltage: 230 V
- Current: 0.4 A
- Frequency: 50/60 Hz
- Noise: 62 dBA

In the interest of product improvement Green Power Solutions reserves the right to change any specification given in this data sheet without notice.