

# GPTR6243

## PHASE CONTROLLED SCR

High reliability operation  
 DC power supply  
 Controlled rectifiers  
 DC drives - Motor starters

**BLOCKING VOLTAGE UP TO**            **5200 V**  
**AVERAGE CURRENT**                **2435 A**  
**SURGE CURRENT**                      **37 kA**

### BLOCKING CHARACTERISTICS

Characteristic		Conditions	Value
VRRM	Repetitive peak reverse voltage		5200 V
VRSM	Non-repetitive peak reverse voltage		5200 V
VDRM	Repetitive peak off-state voltage		5300 V
IDRM	Repetitive peak off-state current, max.	VDRM, single phase, half wave, Tj = Tjmax	200 mA
IRRM	Repetitive peak reverse current, max.	VRRM, single phase, half wave, Tj = Tjmax	200 mA

### ON-STATE CHARACTERISTICS

IT(AV)	Average on-state current	Sine wave, 180° conduction, Th = 55 °C	2435 A
IT(RMS)	R.M.S. on-state current	Sine wave, 180° conduction, Th = 55 °C	3823 A
ITSM	Surge on-state current	Non rep. half sine wave, 50 Hz, VR = 0 V, Tj = Tjmax	37 kA
I²t	I² t for fusing coordination		6845 kA²s
Vt(Tj)	Threshold voltage	Tj = Tjmax	1.1 V
rT	On-state slope resistance	Tj = Tjmax	0.241 mΩ
VTM	Peak on-state voltage, max	On-state current It = 3000 A, Tj = Tjmax	1.82 V
IH	Holding current, max	Tj = 25 °C	300 mA
IL	Latching current, typ	Tj = 25 °C	3000 mA

### TRIGGERING CHARACTERISTICS

VGT	Gate trigger voltage	Tj = 25 °C, Vd = 5 V	1.5 V
IGT	Gate trigger current	Tj = 25 °C, Vd = 5 V	350 mA
VGD	Non-trigger voltage	Vd = 67% VRRM, Tj = Tjmax	0.4 V
PGM	Peak gate power dissipation	Pulse width 0.5 ms	150 W
PG(AV)	Average gate power dissipation		20 W
IFGM	Peak gate current		10 A
VFGM	Peak gate voltage (forward)		10 V
VRGM	Peak gate voltage (reverse)		12 V

### SWITCHING CHARACTERISTICS

di/dt	Critical rate of rise of on-state current	Repetitive, Tj = Tjmax	150 A/μs
dV/dt	Critical rate of rise of off-state voltage	Linear up to to 67% VDRM, Tj = Tjmax	1500 V/μs
tq	Turn-off time, typ	Tj = Tjmax, IT = 2300 A, di/dt = -2 A/μs VR = 200 V, VD = 67% VDRM, dV/dt = 20 V/μs	μs

### THERMAL AND MECHANICAL CHARACTERISTICS

Rth(j-c)	Thermal resistance (junction to case)	Double side cooled	0.009 °C/W
Rth(c-h)	Thermal resistance (case to heatsink)	Double side cooled	0.002 °C/W
Tjmax	Max operating junction temperature		125 °C
Tstg	Storage temperature		-40 / 125 °C
F	Clamping force		48 / 54 kN
	Mass		1500 g

Current rating - sine wave

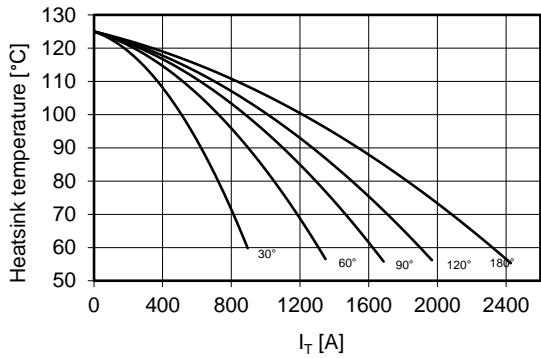

Power loss - sine wave

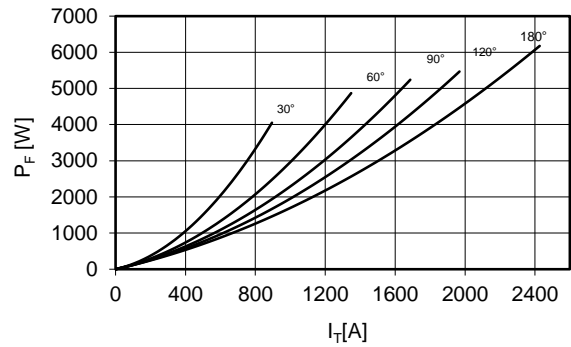

Maximum surge current d.s. cooled

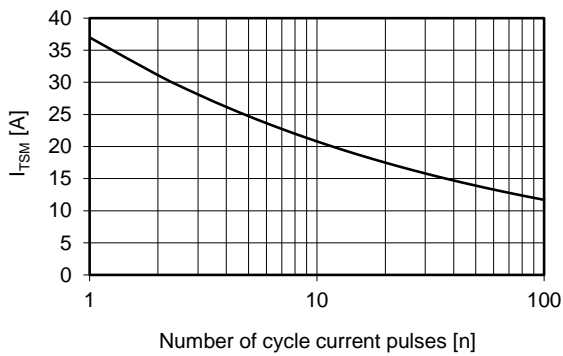

On-state voltage drop

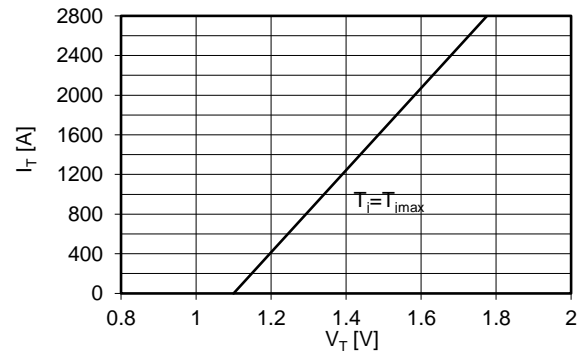

Thermal impedance (j-c)

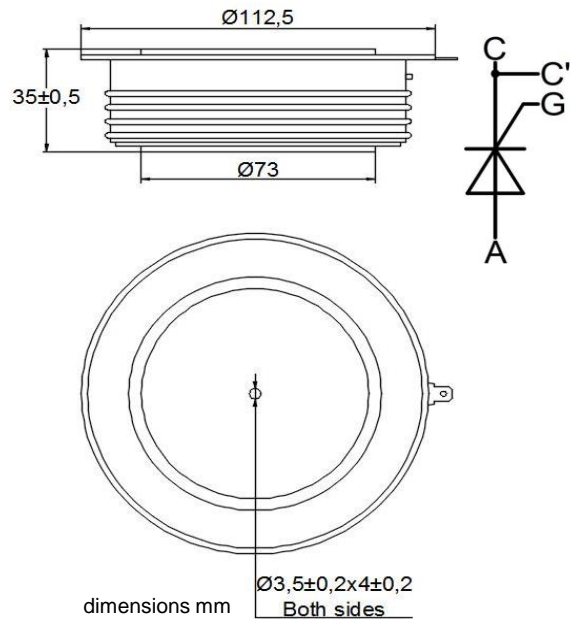
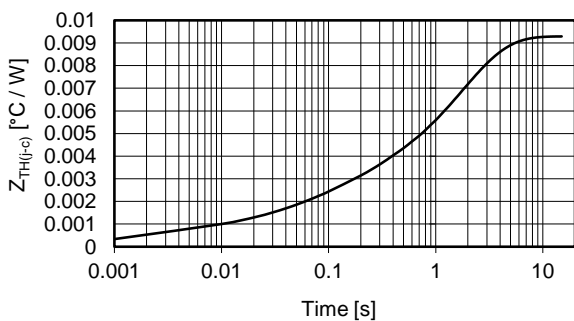

**Ordering information GPTR6243-VVGL**

- VV**: blocking voltage / 100 (e.g. 52 for 5200 V)
- G**: trigger lead type (**S** = straight **T** = twisted **blank** = no leads)
- L**: trigger lead length x 100mm (**3 - 4 - 5 - 7 blank** = no leads)

In the interest of product improvement Green Power Solutions reserves the right to change any specification given in this data sheet without notice.